



# Cornell Institute for Biology Teachers

Copyright CIBT

This work may be copied by the original recipient from CIBT to provide copies for users working under the direction of the original recipient. All other redistribution of this work without the written permission of the copyright holder is prohibited.

Lab issue/rev. date: 6/2011

**Title:**

## Shake and Break: An Earthquake Simulation

**Authors:**

Carol Fleck, John R. Williams Middle School, Painesville Township, Ohio  
 Gerald Matson, Auburn Middle School, Painesville Township, Ohio  
 David McNamara, Shaker Heights High School, Shaker Heights, Ohio  
 Vali Tamm, Department of Geology, Cornell University, Ithaca, New York  
 Development of this lab was supported by the Mastin Foundation, Painesville, Ohio

**Appropriate Level:**

Middle school earth science, grades 6 - 9.

**Abstract:**

An earthquake simulator, or seismic table is constructed and then used to test the structural soundness of several types of student built houses. Several different construction materials are used to demonstrate what type best survives an earthquake. Two different geological foundations, bedrock and water saturated sand, are tested to show the effect of liquefaction on buildings. The model seismic table is useful in gathering data that are representative of actual damage incurred during severe earthquakes.

**Time Required:**

25 minutes to prepare concrete and plaster of Paris building blocks.  
 45 minutes to build the houses  
 45 minutes to test the houses on the seismic table

**Special Needs:**

The seismic table is the only special equipment required. While the table is relatively easy to build, it is available for loan from the CIBT Lending Library.

**NYS Learning Standards:**

1- Inquiry Analysis Design - 2.1.a, b, d; 3.1.a, b; 3.2.d, e, g, h; 3.3  
 4- Needs physical setting standards

## Teacher Information

# Shake and Break: An Earthquake Simulation



### Lab Purpose

1. Build a seismic table to simulate the motions of an earthquake.
2. Build a variety of structures which can be tested for earthquake damage.
3. Describe the amount and type of damage sustained by structures while varying the underlying geological foundation types.
4. Measure the amount of damage sustained by structures of varying type of construction.
5. Measure the amount of damage sustained by structures while varying the frequency of earth vibrations.

### Skills and Activities

1. Use various types of building materials and construction models in the building of a model structure.
2. Observe a model of an earthquake.
3. Record data.
4. Understand the need for civil engineering studies to construct safe housing in earthquake prone areas.
5. Recognize the historical significance of earthquake disasters.

## Background for the Teacher

Models are useful to scientists because they can be used to help understand complex concepts by reducing the components to a more easily understood level. The "seismic table" that is built in this exercise is such a model because it mimics the movements of the earth during an earthquake and allows the students to collect data. It should be noted that this model has limitations, as all models do, because it does not adequately demonstrate all the motions typically found in a damaging earthquake. This model best demonstrates vertical waves, and it should be noted that the most damaging waves are more often horizontal waves. As the teacher moves through this presentation it is appropriate to introduce the type of wave motions found in an earthquake. A slinky can be used to demonstrate and distinguish the waves generated by earthquakes that are detected by seismographs. There are two general types of waves. The first type includes two specific waves that are termed body waves because they travel through the Earth, while the other general type is called a surface wave because it travels on the surface of the Earth. The body waves include the compression waves or P (primary) waves that travel very fast through the Earth and arrive at a seismograph first. The other body waves are the S (secondary) waves, or shear waves, which also travel through the earth but they travel more slowly and thus arrive later. The surface waves, L, are responsible for producing the roll often experienced by observers. The L waves arrive at the seismic station last because they travel the longer distance over the surface of the Earth.

More advanced students might try to actually locate the epicenter of an earthquake by triangulation if given the appropriate data. The epicenter of an earthquake is the point on the surface directly above the focus of the earthquake or the actual point where the fault or weakness occurs. The focal depth can be shallow (from the surface to a depth of 60 km), intermediate (from 60 km to 300 km), or deep (300 km to 700 km.) Shallow earthquakes tend to be the most destructive to surface structures.

The Richter scale and the Mercalli scale can be used to discuss how earth scientists try to measure the severity of earthquakes. Historical perspectives can be introduced by discussing past earthquake disasters. Loss of human life and economic consequences can be ascertained by examining data from past earthquakes. Richter scale readings are mathematically determined from seismograph readings. A modified Richter scale can be made using this model by using the increasing numbers on the motor modulator. An enterprising and clever student or teacher might be able to get a simple seismograph reading using this model. The table below lists the earthquake magnitudes and frequencies of world incidence.

**Table 1. The Richter Scale**

<b>Richter Magnitude</b>	<b>Earthquake Effects</b>	<b>Estimated Number per Year</b>
< 2.0	Generally not felt, but recorded	600,000
2.0 - 2.9	Potentially perceptible	300,000
3.0 - 3.9	Felt by some	49,000
4.0 - 4.9	Felt by most	6200
5.0 - 5.9	Damaging shocks	800
6.0 - 6.9	Destructive in populous regions	266
7.0 - 7.9	Major earthquakes, Inflict serious damage	18
> 8.0	Great earthquakes. Total destruction near epicenter	1.4

Tarbuck, Edward J. and Lutgens, Frederick K. *The Earth: An Introduction to Physical Geology*. New York: Macmillan Publ. Co., 1993. p. 416.

The intensities of earthquakes can be measured using the Mercalli scale which is really a measure of the damage inflicted during an earthquake. This is a scale that runs from I to XII with the lower numbers representing damage done in a small earthquake and the higher numbers indicating more destruction. This scale is not often reported in the general media because it has several deficiencies. Damage in an earthquake lessens as you move away from the epicenter and the underlying geological material in the ground on which structures are built varies and thus affects the amount of damage that occurs. For example, liquefaction greatly increases the amount of damage that can occur to buildings in an earthquake.

Liquefaction can be demonstrated by using sand that is saturated with water. Dry sand behaves like a solid because there is much friction between the individual particles of sand, but when the sand is saturated with water the sand begins to behave like a fluid because the water reduces the friction between the particles. A similar phenomenon can be observed as you walk along a beach barefoot. If you walk near the water where the sand is saturated you tend to sink into the sand leaving a footprint that rapidly fills with water. When you walk on dry sand very little footprint can be observed because the dry sand acts like a solid and better supports your weight. Quicksand is another example of liquefaction. Liquefaction during an earthquake tends to cause the buildings to sink into the sand, especially on one side causing the building to tilt and fall to one side. Some of the most destructive

effects of earthquakes have been attributed to liquefaction. The "seismic" table used in this exercise should produce similar effects.

References to magnitude, damage, and fatalities can be located in many sources. The table below gives data on some significant earthquakes throughout history.

**Table 2. Important Historical Earthquakes**

<b>Year</b>	<b>Place</b>	<b>Deaths</b>	<b>Richter Mag.</b>
1290	Chihli, China	100,000	N.A.
1556	Chen-shu, China	830,000	N.A.
1693	Naples, Italy	93,000	N.A.
1731	Peking, China	100,000	N.A.
1737	Calcutta, India	300,000	N.A.
1906	San Francisco, CA	500	8.3
1908	Messina, Italy	160,000	7.5
1923	Yokohama, Japan	200,000	8.3
1932	Kansu, China	70,000	7.6
1976	T'ang-shan, China	500,000 (?)	8.2
2004	Sumatra	227,898	9.1
2005	Pakistan	86,000	7.6
2010	Haiti	222,570	7
2011	Honshu, Japan	28,050	9

Elastic rebound theory can be introduced for older and more curious students. This theory states that friction along a fault slowly builds until it can no longer prevent the fault from slipping. The frictional lock is broken and an earthquake occurs.

## Procedure

### Construction of the seismic table

Only one or two seismic tables need to be built for the entire class. The teacher or a small group of students can be responsible for this construction.

#### Materials

Two 15 inch square pieces of plywood  $\frac{3}{4}$  in thickness  
4 springs, # 752 made by Century. Available at most hardware stores  
1 aluminum oblong cake pan 9 in x 13 in x 2  $\frac{1}{2}$  in depth  
One electric motor with a variable modulator and an eccentric attached, 0 - 4,000 rpm.  
Nails (#4CC), and wire  
1 roll of duct tape  
2 C clamps, 4 inches

#### Tools

Hammer  
Electric drill with a  $\frac{15}{16}$  inch spade bit

#### Directions:

1. Measure two inches in from each corner of the plywood pieces and use a  $\frac{15}{16}$  inch spade bit to drill a hole about  $\frac{1}{4}$  inch deep (a total of 8 holes).
2. On the piece you will use for the bottom, insert the four #752 springs. Secure the springs by driving a # 4 CC Box Nail at an angle into the plywood.
3. Mount the motor on your top piece in the middle ( $7\frac{1}{2}$ " ) on the opposite side of the holes and about  $\frac{1}{2}$  inch from the edge.
4. Secure the eccentric weight on the shaft of the motor.
5. Mount the top board on the springs and secure it by running a wire through all four springs.  
**This is mostly a safety measure to prevent the top from jumping off the springs.**  
**Cover the wire with Duct tape. Do the same for the bottom as a safety measure.**
6. On the surface of the top piece, fasten 4 strips of wood around your pan to prevent sliding.

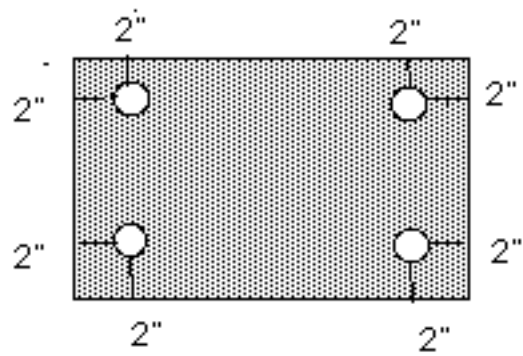

**Diagram A: Bottom View of Seismic Shake Table**

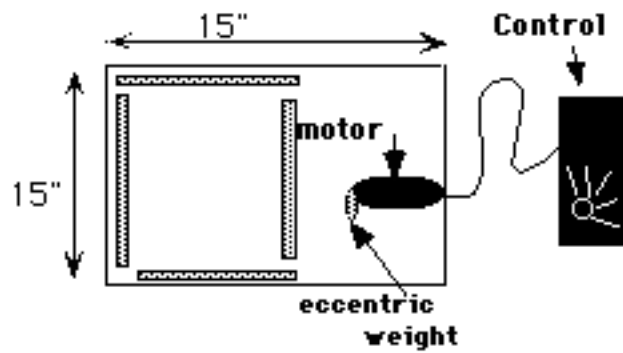

**Diagram B: Top View of Seismic Shake Table**

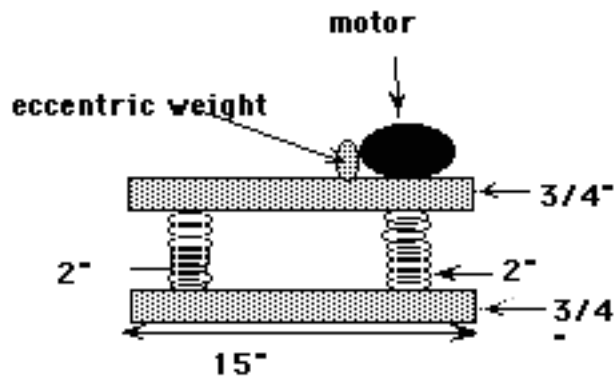

**Diagram C: Side View of Seismic Shake Table**

## Construction of protective motor cage:

### Materials :

piece of hardware cloth  
 2 pieces of wood  $\frac{3}{4}$  x  $\frac{3}{4}$  x 8 inches  
 4# 9  $\frac{7}{16}$  inch staples  
 4 nails 4CC Box  
 4 small nylon ties

### Tools

Tin snips

### Directions:

1. Cut hardware cloth with tin snips to conform with the pattern above.
2. Fold the top and sides to form a rectangle.
3. Fasten the front part to the two sides with 4 nylon ties.(2 top and 2 bottom)
4. Use staples to fasten the cage to the wood strips wrapping  $\frac{1}{2}$  inch under the wood.
5. Fasten the strips to the table on either side of the motor with 4 cc box of nails.

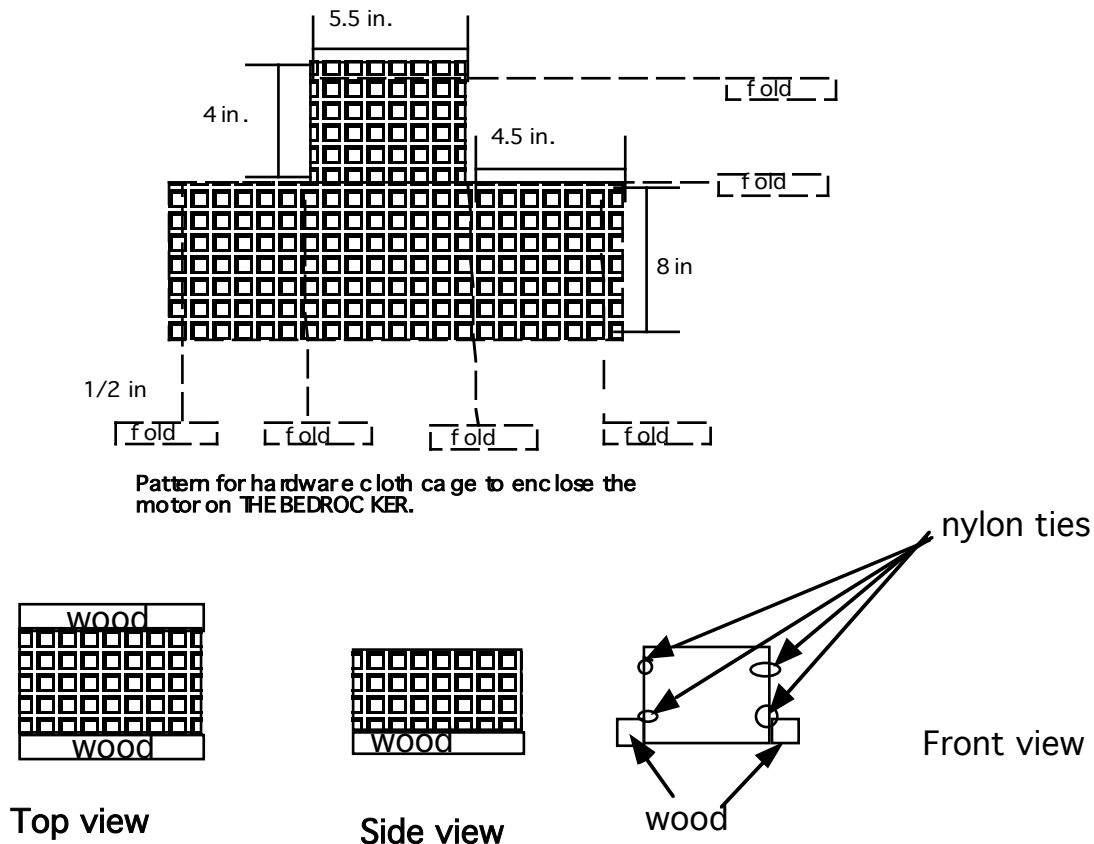

DIAGRAM D: Construction of protective motor cage



## Preparation of building materials and construction of houses

Have the students work in groups of four. Have each group make two houses. They may construct two houses made of the same building materials for testing on bedrock and water, or each group may make two different houses.

### Materials

- 10 pounds of plaster of Paris
- 10 pounds of concrete mix
- 2 pkgs. of 150 "Skill Sticks", snap-apart building sticks (available at craft stores or from Forster MFG Co, Inc., Wilton, Maine 04294
- 18 Plastic ice cube trays that have been cut about 1/2 inch from the top to serve as molds for the building blocks
- 24 paper cups to mix the plaster of Paris
- 1 bag of pop sickle sticks to serve as stirrers and trowels for mortaring
- 24 plastic spoons
- 6 graduate cylinders, 50 ml
- 6 beakers, 250 ml, graduated or measuring cups
- 12 pieces of cardboard cut into 6 inch squares
- 1 roll of wax paper to cover the cardboard
- 1 package of 3x 5 index cards to serve as floors for houses
- 4 quart size Zip Lock freezer bags

### Directions:

1. Allow time for discussion of the variables that you plan to test. Select only a few variables for each section. Be careful not to choose too many variables unless you have the time to do replications.
2. Concrete blocks: Use plastic Zip Lock sandwich bags for mixing the concrete and dispose of them after the molds have been filled. A mixture of 100 ml of concrete with 20 ml of water can be made and placed in the molds. Plastic ice cube trays work well for the molds but they should only be filled to the thickness of a domino piece. Allow 24 hours to dry before removing from the tray. Each student group should make a minimum of four trays of building blocks. The teacher should prepare a few extra trays.
3. Plaster of Paris can be made in a similar way using the recipes given in the student section. Try to keep all the building blocks the same size. After they have dried for 24 hours, simply snap the blocks from the bottom of the ice cube trays. All the building blocks should be prepared several days in advance of testing on the seismic table to allow time for construction of houses. Preparation of the building blocks should take about 25 minutes of class time. Allow time on the next day for a "creative" architecture session of house building following the guidelines given in the student section.

4. Bricks can be mortared using plaster of Paris. Plaster of Paris dries very quickly so the students should be prepared to quickly assemble the houses. It is best to add the dry plaster of Paris to water and you may need to add more water after the first batch is made in the paper cup. Dispose of the paper cups.
5. Other materials can be used to make buildings, but they should be tested by the teacher first.

# Testing the houses on the seismic table

## Materials:

Seismic table with eccentric motor  
1 cake pan filled with saturated sand  
Timer  
Tables to record the data  
Student built houses  
Staple gun with 3/8 inch staples

## Directions:

1. Have the students prepare a table to record observations using the variable you have selected.
2. On the day that you test the structures on the seismic table, have each group approach the table with their houses. One member should be assigned the task of timing, while another can operate the table. The third student can record the data and the fourth can be responsible for placing the structure on the table.
3. The structures that are to be tested on bedrock can be stapled directly to the seismic table through the cardboard.
4. To test the structures on sand, load the pan with saturated sand onto the table and anchor it in place.
5. A few descriptive words can be given to help the students record consistent qualitative observations, such as: tilting, sinking, twisting, etc. Record the time that the structure fell.

## Safety Notes

1. If students help with the building of the seismic table they should be closely supervised. It is probably best to have an adult build the seismic table.
2. A GFI outlet should be used since the students have an electric motor near water.

## Estimated Amount of Time for Lab

25 minutes for building the blocks in the molds for construction.  
One class period to build the houses.  
One class period to test the houses and record the data

## **Teaching Tips and Logistics**

1. Student groups of four can be utilized. Each group should build two houses. Cooperation is demanded within each group and various roles can be assigned.
2. There should be replicates in the class. This can be done by having each group build two identical houses or having two different groups build the same type of house.

## Assessment for the Lab Along With Rubrics

1. Accuracy of the recorded data and critical analysis as evidenced by the discussion of the results.
2. Graphs of the plotted data.

## More Ideas and Extensions

1. Have the students construct a relative Mercalli scale and Richter Scale using the seismic table and use these scales to measure the intensity and damage of simulated earthquakes.
2. Relate the type of construction and underlying geological support to geographical areas where seismic activity is frequent. Use a variety of construction materials (stucco, adobe, mud, interlocking vs. stacked blocks, etc..) and architectural styles. Critically analyze the need for building regulations in areas with significant seismic activities.
3. Build and use a simple seismograph to record the activity of an earthquake.
4. The chemistry of concrete, while fairly complicated, might be studied by capable students.
5. The causes of human fatalities in earthquakes can be explored.
6. Tsunami waves can be investigated.
7. Earthquakes can be related to orogeny and the theory of plate tectonics.

# Shake and Break: An Earthquake simulation

## New York State Learning Standards

High School

### **Standard1: Analysis, Inquiry, and Design**

**Key Idea 2:** Beyond the use of reasoning and consensus, scientific inquiry involves testing of proposed explanations involving the use of conventional techniques and procedures and usually requiring considerable ingenuity.

- 2.1 Use conventional techniques and those of their own design to make further observations and refine their explanations, guided by a need for more information.
  - a. Demonstrate appropriate safety techniques
  - b. Conduct an experiment designed by others
  - d. Use appropriate tools and conventional techniques to solve problems about the natural world, including: measuring, observing, describing, classifying, sequencing

**Key Idea 3:** The observations made while testing proposed explanations, when analyzed using conventional and invented methods, provide new insights into phenomena

- 3.1 Use various methods of representing and organizing observations (e.g., diagrams, tables, charts, graphs, equations, matrices) and insightfully interpret the organized data.
  - a. Organize results, using appropriate graphs, diagrams, data table, and other models to show relationships
  - b. Generate and use scales, create legends, and appropriately labeled axes
- 3.2 Interpret the organized data to answer the research question or hypothesis and to gain insight into the problem
  - d. Formulate and defend explanations and conclusions as they relate to scientific phenomena
  - e. Form and defend a logical argument about the cause-and-effect relationships in an investigation
  - g. Suggest improvements and recommendations for further studying
  - h. Use and interpret graphs and data tables
- 3.3 Assess correspondence between the predicted result contained in hypothesis and actual result, and reach a conclusion as to whether the explanation on which the prediction was based is supported

# SHAKE AND BREAK- An Earthquake Simulation

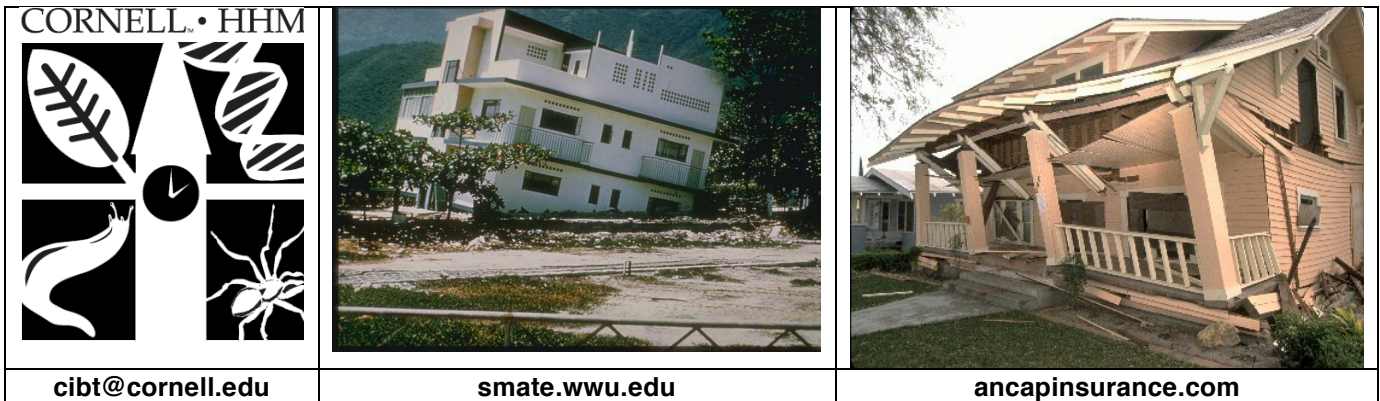

## Purpose of the Lab

1. How can we use a seismic table to demonstrate the behavior of different building structures during an earthquake?
2. How can we measure the damage inflicted upon structures during an earthquake?
3. How can we assess the damaging effects of an earthquake when the houses rest on different types of geological foundations?

## Background for the Student

Scientists often use models to help them understand ideas that are complex, very big, or very small. Models of atoms (which are very small) can be built to help understand the structure of an atom. Biologists often use models of cells to understand the very fine structures found inside the cell. Astronomers use models of our solar system (which is very big) to show how the planets are arranged around the sun. Engineers use models of airplanes to show how a plane will function in flight. In this exercise you will use a "seismic" model to show how an earthquake causes damage. Since earthquakes are massive events, it is helpful to reduce the events to a smaller scale so that earth scientists can study their effects.

Earthquakes have been recorded in most parts of the world, but there are some areas where earthquakes occur more frequently than others. In general, the western part of the United States, especially California and Alaska, have more earthquakes than other regions. The most serious earthquake in the Eastern United States occurred in Charleston, South Carolina in 1886, killing 60 people. Even the Midwest has a seismic zone centered around New Madrid, Missouri, where several very disastrous earthquakes have happened. Other countries, especially those with mountain ranges near the coastline

have many serious earthquakes. It is estimated that over 500,000 people died in an earthquake in China in 1976.

Why do so many people die each year in earthquakes? There are several answers to this question. One answer is related to the type of building material that is used to build houses, offices, and apartment buildings. Building materials vary from one region to another depending upon what is available and how expensive it is. In some areas most of the structures are wood and in other areas masonry buildings are more often built. In underdeveloped countries adobe mud bricks, and stones can be found in many of the structures. Not all construction materials behave in the same way during an earthquake. Wood, if used in the proper way, can be a surprisingly strong building material while masonry building can fall easily if not properly built. Modern masonry skyscrapers have been designed to endure strong earthquakes. You will test several types of construction materials in this laboratory activity.

Another answer to the question can be discovered by examining the type of geological foundation material used for buildings. Solid rock or bedrock is a very effective foundation, but solid rock often lies far below the surface making it difficult to place the foundation there. Loose foundation material such as sand which can become saturated with water is a particularly dangerous situation. Dry sand behaves like a solid because there is much friction between the individual particles of sand, but when the sand is saturated with water the sand begins to behave like a fluid because the water reduces the friction between the particles. This is called **liquefaction**. A similar phenomenon can be observed as you walk along a beach barefoot. If you walk near the water where the sand is saturated you tend to sink into the sand leaving a footprint that rapidly fills with water. When you walk on dry sand very few footprints can be observed because the dry sand acts like a solid and better supports your weight. Quicksand is another example of liquefaction. Liquefaction during an earthquake tends to cause the buildings to sink into the sand, especially on one side causing the building to tilt and fall to one side. Some of the most destructive effects of earthquakes have been caused by liquefaction. You will demonstrate liquefaction in this exercise.

Big earthquakes can cause widespread destruction in highly populated areas. The amount of energy released in large earthquakes is many times more powerful than the explosion of many atomic bombs. In a brief burst of energy, massive buildings over a wide area can be destroyed. The forces to do that much damage are tremendous. The **Richter Scale** has been developed to measure the amount of energy released in earthquakes. The Richter Scale is described in the table that follows.

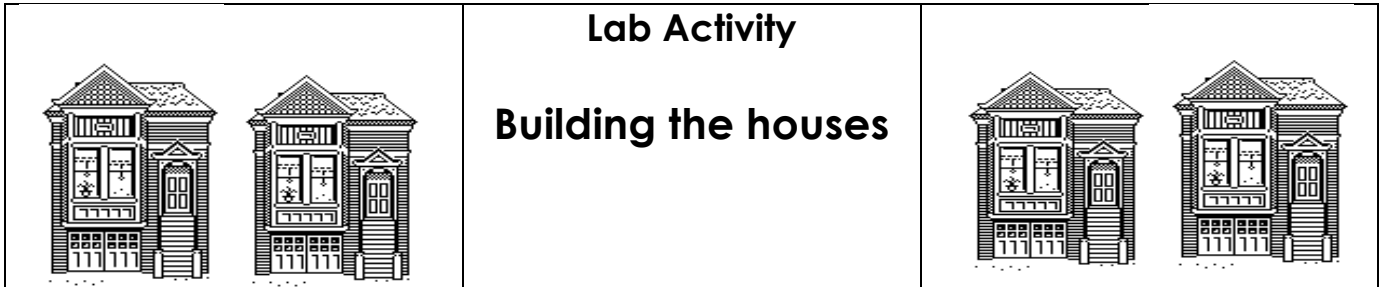

**Table 1. The Richter Scale**

<b>Richter Magnitude</b>	<b>Earthquake Effects</b>	<b>Estimated Number per Year</b>
< 2.0	Generally not felt, but recorded	600,000
2.0 - 2.9	Potentially perceptible	300,000
3.0 - 3.9	Felt by some	49,000
4.0 - 4.9	Felt by most	6200
5.0 - 5.9	Damaging shocks	800
6.0 - 6.9	Destructive in populous regions	266
7.0 - 7.9	Major earthquakes, Inflict serious damage	18
> 8.0	Great earthquakes. Total destruction near epicenter	1.4

Tarbuck, Edward J. and Lutgens, Frederick K. *The Earth: An Introduction to Physical Geology*. New York: Macmillan Publ. Co., 1993. p. 416.

Most often we tend to think of earthquakes as being only destructive. But it is important to remember that earthquakes are constantly changing the surface of the earth and they help build mountains. Living through an earthquake may not be pleasant, but the resulting scenery can be quite beautiful.



You will work in groups of four students. Each group will build only two houses. Check with your teacher to decide what type of houses to construct.

### Wood Houses

#### Materials

- \* 100 "Skill Sticks", snap-apart building sticks, broken into small sizes

#### Procedure

For wood structures use the interlocking wood sticks that have been broken into pieces. It is not necessary to place a floor between levels. If your model is to be tested on bedrock, mortar the wood structure directly to the cardboard. Do not mortar the structure that is to be placed on the saturated sand.

### Concrete or Plaster of Paris Houses

#### Materials

- \* 250 ml of plaster of Paris or\* 300 ml concrete mix
- 3 Plastic ice cube trays that have been cut about 1/2 inch from the top to serve as molds for the building blocks
- 1 paper cups to mix the plaster of Paris
- 1 quart size Zip Lock freezer bag to mix concrete water
- 2 pop sickle sticks to serve as stirrers and trowels for mortaring
- 2 plastic spoons
- 1 graduated cylinder, 50ml
- 1 beaker, 250 ml, graduated or measuring cup
- 8 pieces of 3x 5 index cards that have been cut into thirds along their width
  
- 2 pieces of cardboard cut into 6 inch squares
- 2 pieces of wax paper to cover the cardboard

## Procedure

1. If you are making concrete or plaster of Paris houses, lay three ice cube trays on a piece of waxed paper which is wrapped around a piece of cardboard.
2. To make concrete blocks, mix 300 ml of concrete with 55 ml of water in a Zip Lock bag. Thoroughly mix the dry concrete with the water for several minutes until it is thoroughly mixed. Remove any large stones if necessary. Spoon the concrete mixture into three molds making each brick about the size of a domino. Set aside and allow to dry for 24 hours.
3. To make plaster of Paris blocks, pour 75 ml of water into a paper cup and add 200 ml of the dry plaster of Paris. Thoroughly mix with a pop sickle stick. Work very quickly to fill the three molds. Set aside and allow to dry for 24 hours.
4. On the next day, remove the masonry blocks from the bottoms of the molds. Broken pieces can be used if they are mortared.
5. Obtain a paper cup and make a fresh mixture of plaster of Paris mortar according to the directions given above.
6. If your house will be tested on bedrock, obtain a piece of cardboard without wax paper. Mortar your house directly to the cardboard with plaster of Paris. If your house will be tested on water saturated sand, obtain a piece of cardboard covered with wax paper. Mortar your house on top of the wax paper. The wax paper makes it easier to remove the houses.
7. Use a pop sickle stick to lay a line of mortar as a foundation. Work quickly because the plaster of Paris dries very fast. Stand one brick on its long edge in the foundation mortar and then mortar three more bricks to form a rectangular base. Mortar the top edge of each brick and lay a cut 3 x 5 file card to serve as a floor. Continue to build your house so that it has at least four stories with a floor in between layers. You may use a model or the drawing shown below. Set aside and allow to dry for 24 hours.

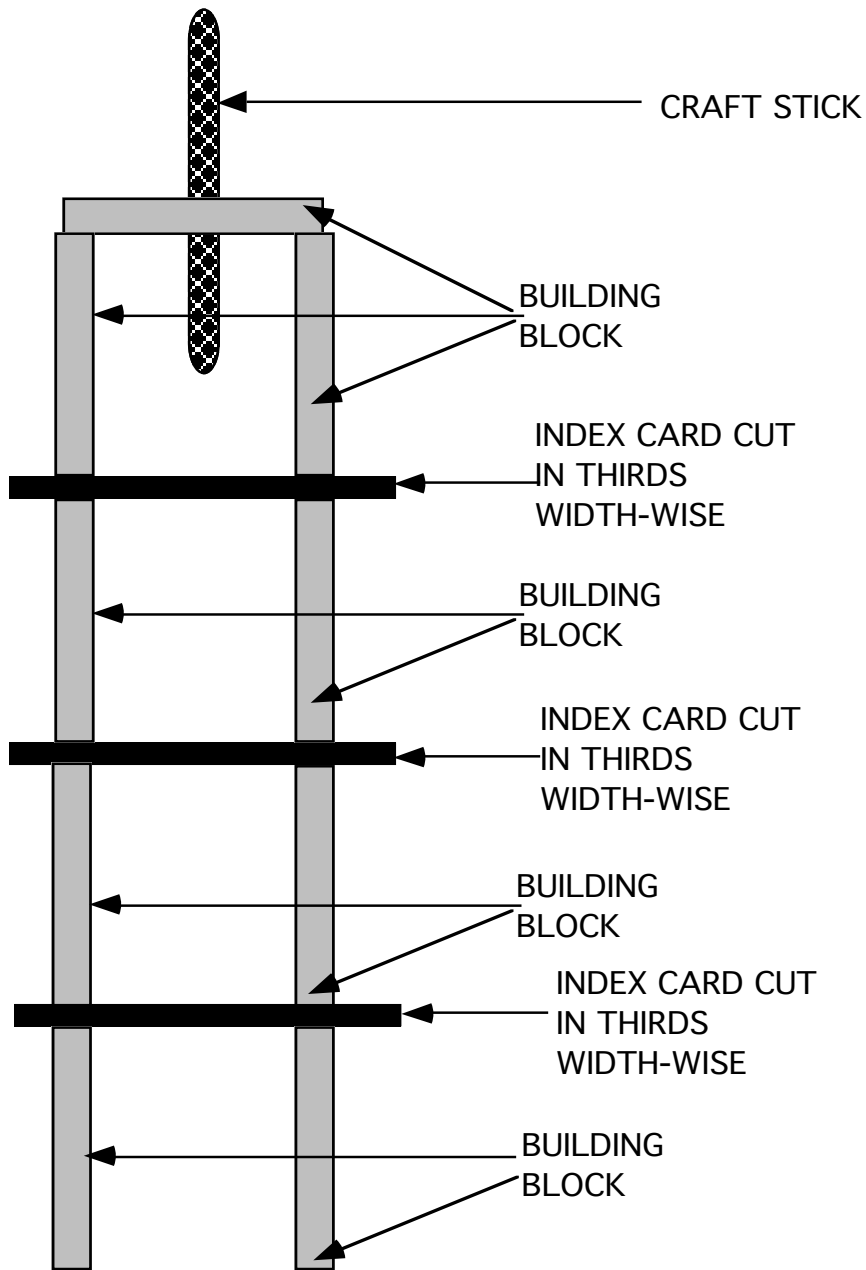
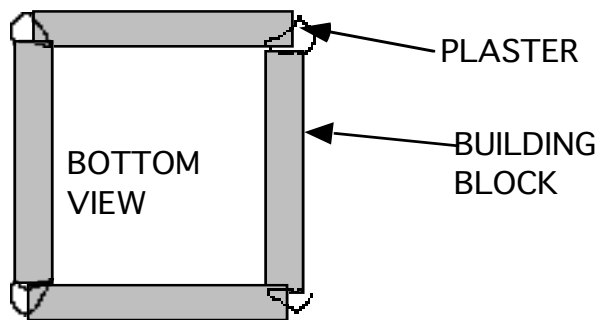

DIAGRAM FOR CONSTRUCTION OF PLASTER OR CONCRETE HOUSE-  
FOLLOW DIRECTIONS FOR BASE (SIDE VIEW)



# Testing the houses on the seismic table.

## Materials

Seismic table with eccentric motor  
1 cake pan filled with saturated sand  
Timer  
Tables to record the data  
Student built houses  
Staple gun with 3/8 inch staples

## Procedure

### The seismic table

Your teacher has prepared the seismic table. Observe the table and read the directions before using.

1. One member of the group should serve as the timer, another should operate the table, another should record the results, and the fourth member is responsible for placing the structures on the table.
2. Start the table at speed # 2 and continue for 20 seconds. Increase the speed to # 3 for 20 seconds and continue with 20 second periods at higher speeds until the house falls.
3. The recorder should write as many observations in the table as possible.
4. Record the total number of seconds at the time the house falls or is broken. See the data table on the next pages.
5. For each house plot the time for destruction on the horizontal axis and speed on the vertical axis. Use a different symbol for each plot. Collect data from the entire class and plot on the graph.

## Safety Notes

AVOID TOUCHING THE MOTOR OR MODULATOR WITH WET HANDS.



## Questions

1. What type of construction is the strongest? Suggest a reason.
2. What type of construction is the weakest? Suggest a reason.
3. How did the wet sand foundation affect the type of damage?
4. If you were to build a house in a seismic area, how would you build your house?
5. Ask your parents if they carry insurance for earthquake damage. Discuss the advantages and disadvantages.
6. Write a building code for apartment buildings in earthquake active areas. Use evidence from your laboratory experiment to support your code.
7. What part of your houses was the weakest? Suggest a way to strengthen this defect.
8. Select another variable that was not tested and describe how you would test it.

9. Describe how you could improve the controls in this experiment.

10. What is the safest behavior in an earthquake? Where would you go?

## More Ideas and Extensions

1. Relate the type of construction and underlying geological support to geographical areas where seismic activity is frequent. Use a variety of construction materials (stucco, adobe, mud, interlocking vs. stacked blocks, etc..) and architectural styles. Critically analyze the need for building regulations in areas with significant seismic activities.
2. Build and use a simple seismograph to record the activity of an earthquake.
3. Research the chemistry of concrete
4. Learn about the causes of human fatalities in earthquakes.
5. Investigate Tsunami waves.
6. Earthquakes can be related to orogeny and the theory of plate tectonics.





## References

- Bolt, Bruce A. *Earthquakes*. New York: W.H. Freeman, 1988.
- Bourgeois, Paulette, (1990). *The Amazing Dirt Book*. New York: Addison-Wesley Publishing Company, Inc.
- Earthquakes: A Teacher's Package for K-6*. The National Science Teachers Association. Washington, D. C. 1988.
- Pakiser, Louis C. "Earthquakes" U. S. Government Printing Office. 1991 - 293-521.
- "The Severity of an Earthquake" U. S. Government Printing Office. 1991 -292-795 QL 3.
- Tarback, Edward J.. Lutgens, Frederick. *The Earth: An Introduction to Physical Geology*.. New York: Macmillan Publ. Co. 1993
- Vogt, Gregory. *Predicting Earthquakes*. New York: Franklin Watts. 1989.
- Walker, Jearl. "How to Build a Simple Seismograph to Record Earthquake Waves at Home." *Scientific American*, vol. 241, no 1, p. 152-161.

## Web Resources

<http://earthquake.usgs.gov/earthquakes/>

<http://en.wikipedia.org/wiki/Earthquake>